

手搖式裁斷機 , 自動帶式電容裁斷機

Hand-crank and Motorized Radial Component Cutting Machine

- RT-79 及 RT-70 為一種操作簡便、維修容易的帶式電容剪腳機。
- 不需要特殊的工具輔助即可使用，是生產線上的好幫手。
- 美觀、輕巧的設計，可直接放在加工桌面上使用。
- 堅固結構的設計，配合耐磨損的滾輪式切刀。
- 提供穩固的使用保證，在加工的過程中不會傷害到零件。

配合不同的紙帶孔徑距離的規格, 此機種有適用於：

Dimension: 380(L) x 180(W) x 210(H)mm

Net Weight: 6 kgs

Production Rate: 25,000 pcs/hr

Unit : mm

	標準型Standard			特殊型Special		
型號Model	RT-70 / RT-79			RT-70S / RT-79S		
尺寸Size	L	d	A	L	d	A
最小Min	2	0.3	12.7	2	0.3	15
最大Max	10	1.2	12.7	10	1.2 </td <td>15</td>	15

RT-7x series of high-speed motorized and hand-crank radial lead cutters offer easy, no tooling required set-up. These machines neither score or damage component leads nor lace mechanical stress or axial tension on the component. The machine cuts components from single bandoleers with a fully adjustable lead length, from 2 mm to 10mm, and the blade will accommodate lead from 0.3 mm to 1.2 mm.

- Independent rotary disc cutters extend longer cutting life.
- Won't score or damage leads or components.
- Heavy duty construction.
- Easy maintenance.
- Simple operation.

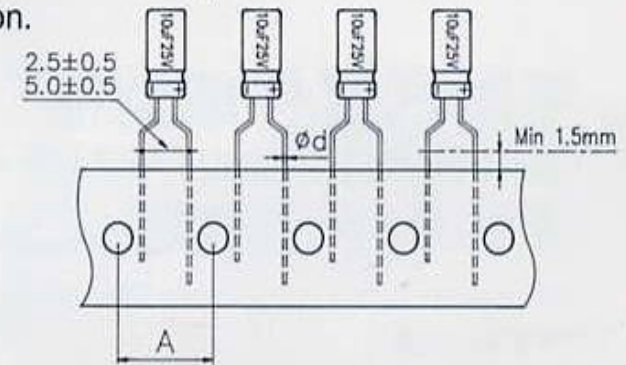

RT-79
RT-79S



RT-70
RT-70S